



For use in:

- PV Solar Cell Positioner
- Wind Energy Systems
- Packaging Machinery
- Motorsport Vehicles
- Automotive Testing
- Factory Automation
- OEM Test Stands

LR-19 Series Linear Position Sensor

More Sensor for Less

The LR-19 series inductive linear position sensors by Alliance Sensors Group are contactless devices designed for factory automation and a variety of industrial or commercial applications such as motor sport vehicles, automotive testing, solar cell positioners, wind turbine prop pitch and brake position, and packaging equipment. With their compact design, superior performance, and excellent stroke-to-length ratio, LR-19 sensors are ideal for both industrial testing laboratories and OEM applications.

LR-19 series sensors are offered in 6 full scale ranges from 25 to 200 mm (1 to 8 inches). Operating from a variety of DC voltages, these sensors offer a choice of four analog outputs and all include ASG's proprietary Sen-Set™ field recalibration feature. LR-19 series products are available with axial cable or connector terminations, or with a radial exiting cable and two swivel rod eye ends for easy installation.

The LR series also includes a larger body version, the LR-27, for those applications needing a heavier duty unit. Technical data sheets and additional information can be found at www.alliancesensors.com.

Features:

- Contactless operation prevents wearout from dither or cycling
- Excellent stroke-to-length ratio
- 19 mm (0.75 inch) diameter anodized aluminum housing sealed to IP-67
- Radial cable exit version comes with swivel rod eye ends
- Axial termination versions with either M-12 connector or 1 m cable
- 10-32 or M5 X 0.8 male or female thread on end of axial operating rod

Specifications:

Analog I/Os	0 - 3 V output with 5 V input, 35 mA max. 0 - 5 V or 0.5 - 4.5 V output with 8 -30 V input, 35 mA max. 0 -10 V output with 12 - 30 V input, 35 mA max. 4 - 20 mA (3-wire) output with 18 - 30 V input, 60 mA max. (75 C max.)
FS Measuring Ranges	25, 50, 75, 100, 150 and 200 mm (1, 2, 3, 4, 6, and 8 inches)
Linearity Error	≤±0.15% of FSO
Resolution	0.025% of FS
Bandwidth	500 Hz update rate (nominal)
Operating Temperature	-20 to 85 C (-40 to 105 C extended temperature range)
Vibration	5 -20 Hz, 0.5 inch p-p; 20 -2000 Hz, 4.2 g p-p
Shock	1000 g, 11 msec
Environmental Sealing	IEC IP-67

LR-19 Series

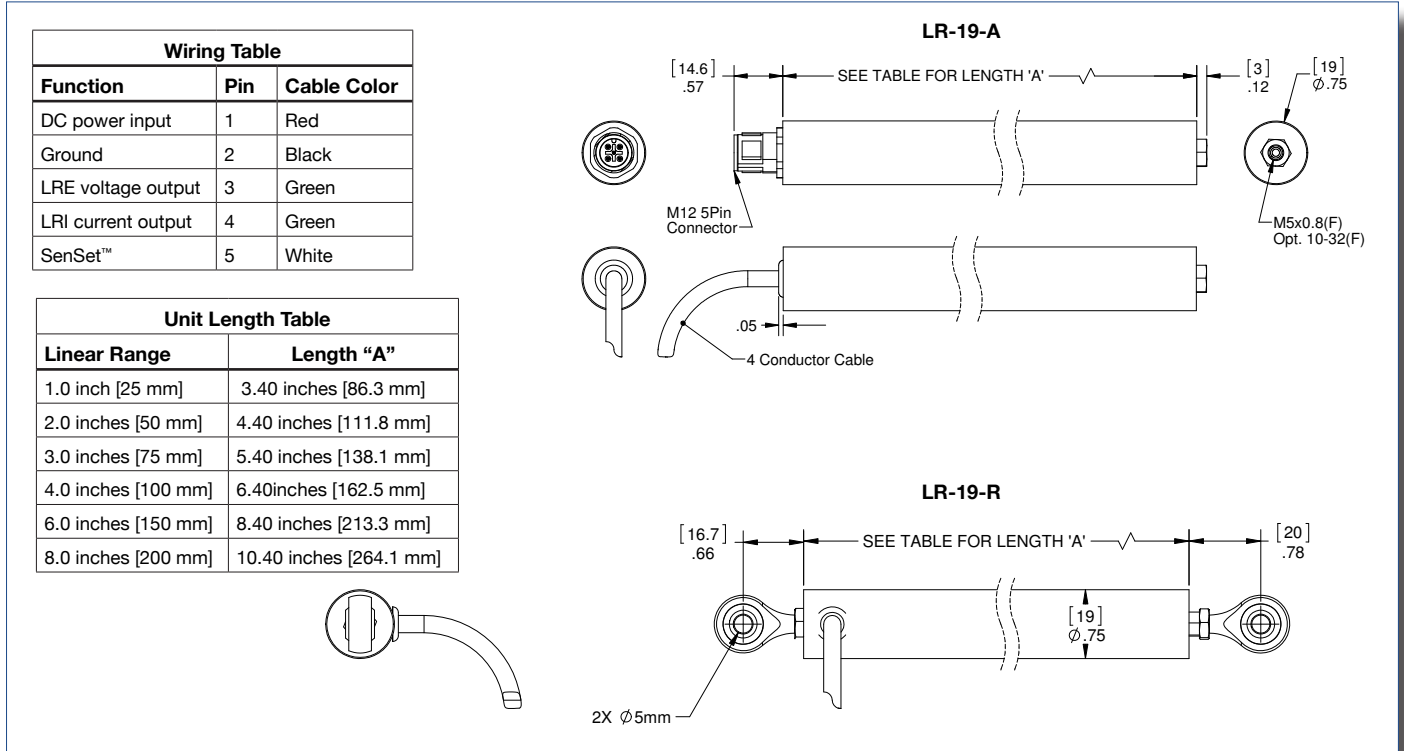

Ordering Information:

Series	Output Type	Body Diameter	Range, Metric	Electrical Termination		Output	Housing Material
				Axial or Radial	Cable or Connector		
LR	X-	XX-	XXX-	X-	XX-	XX-	X-
LR	E - Voltage	19 - 19mm	025 - 25 mm	A - axial	00 - 1-m cable	03 - 0-3 VDC	A - Aluminum
	I - Current		050 - 50mm	R - radial	01 - 5-pin M12	04 - 3-0 VDC	S - Stainless Steel
			075 - 75mm			05 - 0.5-4.5 VDC	
			100 - 100mm			06 - 4.5-0.5 VDC	
			150 - 150mm			10 - 0-10 VDC	
			200 - 200mm			11 - 10-0 VDC	
						20 - 4-20 mA	
						21 - 20-4 mA	
						50 - 0-5 VDC	
						51 - 5-0 VDC	

ALLIANCE SENSORS GROUP
A DIVISION OF H.G. SCHAEVITZ LLC

Alliance Sensors Group
102 Commerce Drive, Unit 8
Moorestown, New Jersey 08057 USA
Ph: 856-727-0250
www.alliancesensors.com
info@alliancesensors.com