

**Sensor box containing two sensors and two signal conditioners with 4...20mA, 2-wire outputs**

## Features

- robust pressure die cast aluminium housing (IP65) with saltwater proof coating
- twist free 4-point fastening of rigid, 3.2mm thick base PCB
- two integrated signal conditioners with 4...20mA, 2-wire outputs
- temperature drift compensation
- no separate supply voltage necessary
- all SEIKA sensors of the B-, BD- and N-series fit the housing and can be installed in different directions of operation
- output signals calibrated to customer's specifications
- sensors and signal conditioners electrically isolated from housing
- both output channels are electrically isolated from and independent of each other
- EMC certified
- internal, highly stable sensor supply voltages
- 10V ... 30V terminal voltage
- programmable dynamic response
- loop current limitation
- high mechanical overload resistance
- either connection polarity - possibility of 3-wire connection for both measuring loops
- low pass filter with optional choice of cut-off frequency for suppression of interference frequencies

## Description

The SB2I is a pressure die cast aluminium sensor housing (IP65) with two integrated sensors for measuring inclinations and/or accelerations along two axis.

As well as the sensors, the box contains two independent signal conditioners, each with a 4...20mA, 2-wire output, and two separate, highly stable voltage supply feeding off the corresponding current loop, one for each sensor. Furthermore, each signal conditioner includes an active low pass filter, whose upper cut-off frequency / settling time can be adjusted to suit the measurement task, an output stage with current limitation, a noise voltage filter and a diode bridge for unipolar connection to the current loop. Interference signals caused by unwanted ground currents are eliminated by electrically isolating each sensor and signal conditioner from each other and the housing.

A special electronic temperature compensation system can significantly reduce the temperature sensitivity of the implemented sensors. The compact PG cable gland and small housing size in combination with the 3-wire connection enable the use of this high quality measuring system in harsh operating conditions.

## Application

The SB2I is suitable for applications requiring precise inclination or acceleration measurements along two axis under harsh circumstances and returning of a 4...20mA output signal each. Areas of successful implementation include construction, mining, agricultural machinery, transportation and conveyor systems, ships, operation and automation technology as well as general mechanical engineering.

**Technical Specifications**

|   |   |
|---|---|
| Terminals                               | 6 x 1,5 mm <sup>2</sup>                             |
| Cable fixing                            | M12 x 1.5 cable gland, clamping range 6mm ... 7.5mm |
| Measuring range, Resolution, etc.       | depends on implemented SEIKA sensors                |
| Degree of protection                    | IP65  |
| Mounting orientation                    | any   |
| Measuring planes (N.. sensors)          | 3 main housing planes                               |
| Measuring directions (B., BD.. sensors) | In X,Y,Z coordinate of housing                      |
| Terminal voltage                        | 10V ... 30V   |
| Minimum loop currents                   | 2.5mA ... 3.5mA                                     |
| Maximum loop currents                   | 22mA ... 26mA                                       |
| Output signal loop current              | 4mA ... 20mA (12mA for zero position)               |
| Adjustable variables                    | zero point (12mA), amplification                    |
| Maximum load resistances                | 500_ohm (at 24 Volt supply voltage)                 |
| Low pass filter                         | Active, 3rd order, minimal ripple                   |
| Operating temperature                   | -40°C ... +85°C                                     |

Options: special measuring ranges, calibration record, silicon encapsulation, custom wiring

**Dimensions (in mm)**

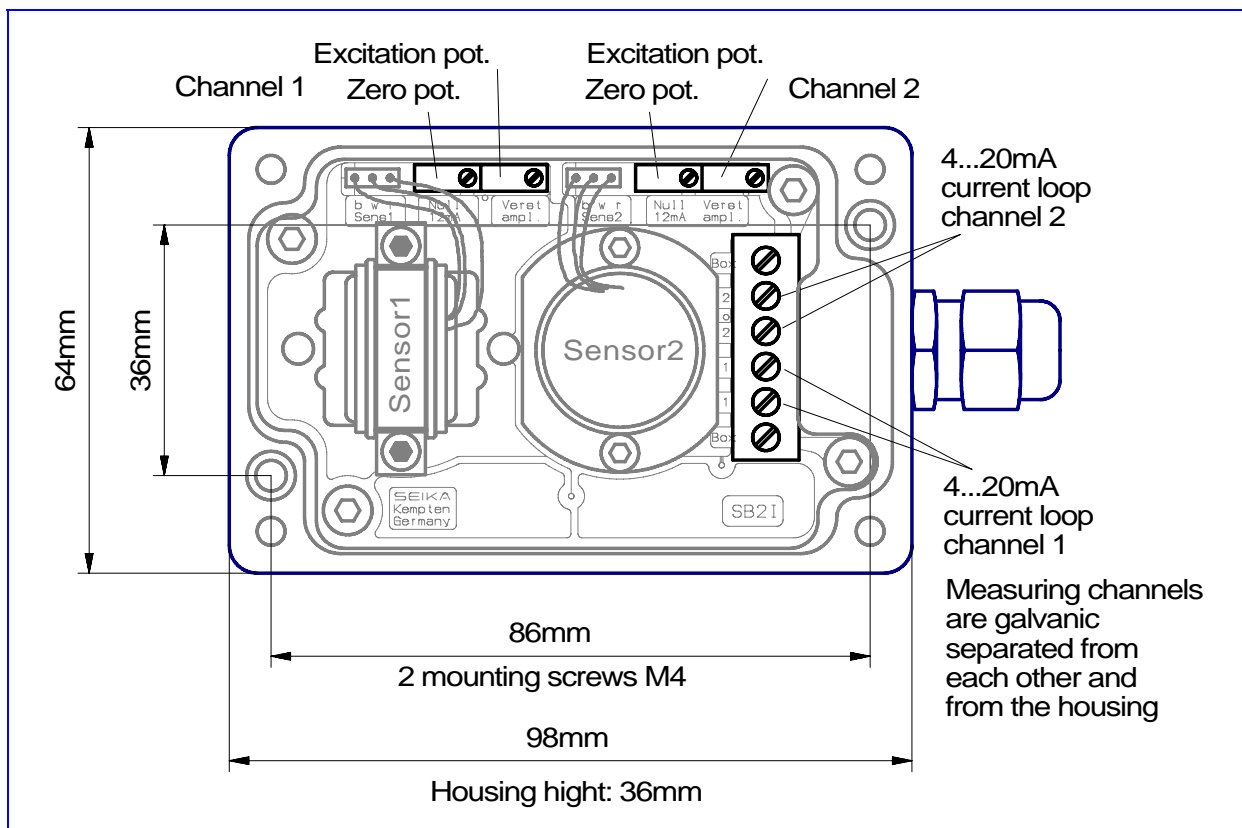

**Block Diagram**

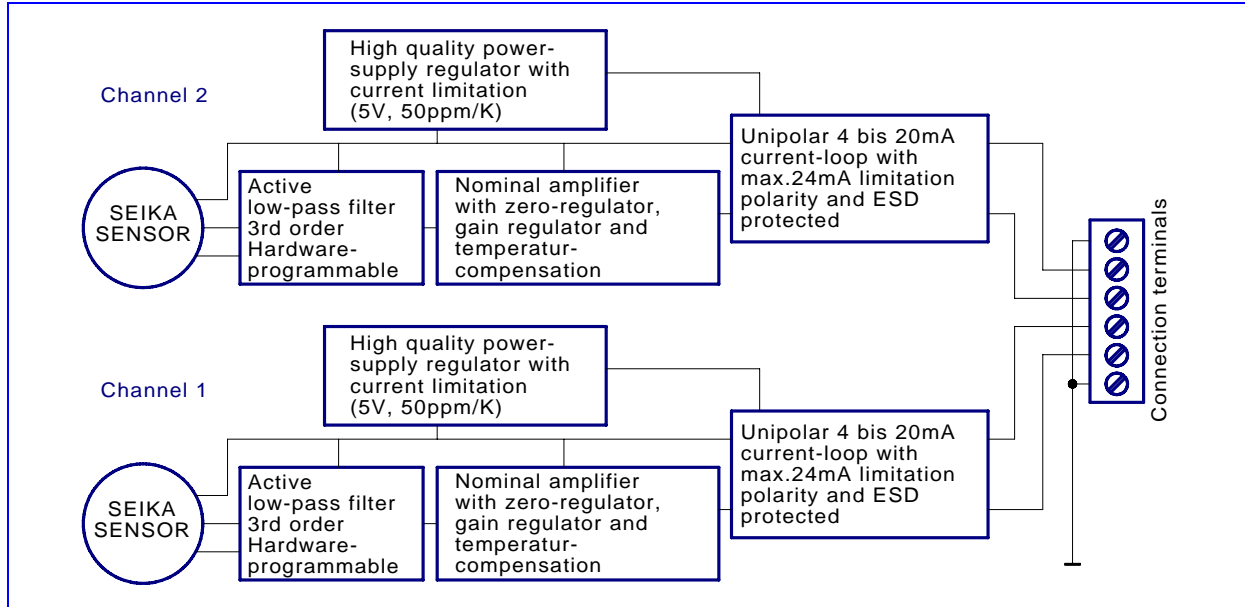

**Connections**

**Current-loop diagram**

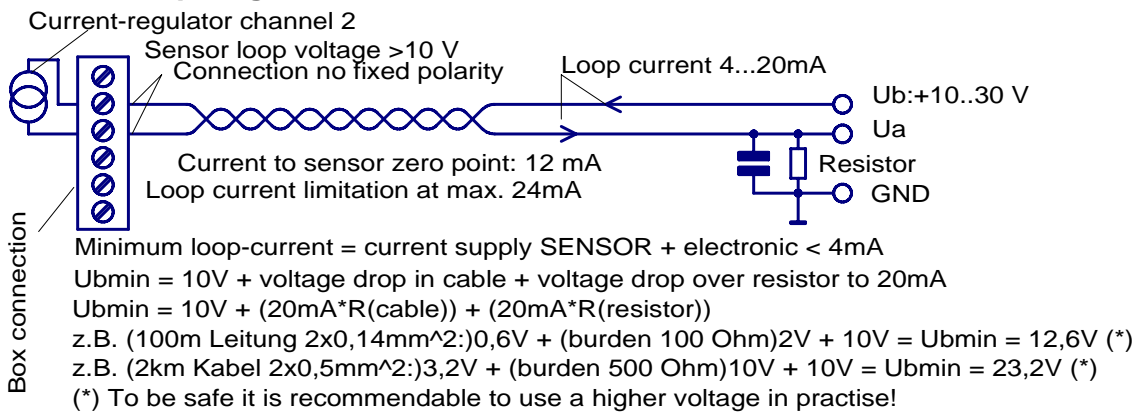

**Two current-loops with 3 connections**

